

# PLEUGER



Pleuger Solutions in  
the Mining Industry



## PLEUGER INDUSTRIES

Since 1929, Pleuger Industries have developed and manufactured pumping solutions to the mining industry's highest standards. We guarantee that our submersible motor pumps and marine propulsion systems perform safely and efficiently, even under extreme conditions.

When Friedrich Wilhelm Pleuger patented his first submersible pump 90 years ago, it broke new ground. The water-filled engine, which could pump water from great depths and narrow wells, was used in the construction of the Berlin subway in the 1920s. Pleuger's Hamburg-based company has since specialized in built-for-purpose products that continue to draw upon his pioneering designs.

Companies worldwide use Pleuger's hydraulic pumps for their municipal water supplies, flood protection, mining, offshore wind farms and oil rigs. Thousands of ships and platforms apply Pleuger Industries' pumps and manoeuvring systems. Whatever your request, we deliver cost-effective solutions that minimize risk and optimize return over an operation's lifecycle.

## CUSTOM-MADE ENGINEERING SOLUTIONS FOR DEWATERING AND WATER SUPPLY APPLICATIONS

Our Centre of Excellence offers quality design, engineering, manufacturing and service for dewatering and water supply applications in the mining sector. With every one of our worldwide projects, we exceed client expectations by saving both time and money while improving value.

We put our clients front and centre with custom solutions for any need. Our decades of experience in manufacturing electric submersible motors make us a trusted partner for customized mining solutions.

### Our advantages at a glance

- 90+ years of experience
- Worldwide reach
- Quality engineering from Germany
- State-of-the-art Research & Development Centre
- Sustainable, durable and maintenance-free solutions
- 6 MW (8,046 HP) design capability
- Committed aftercare

# OUR 360° SUBMERSIBLE PUMPING SOLUTIONS

## Inclined pumping in open-pit mines

Pleuger's inclined pumping systems are a cost-effective alternative to vertical turbine pumps. As they do not need shaft support structures or operating buildings, our systems significantly reduce overall project costs. Mount our versatile units at angles of up to 90° on slope rail systems and intake caissons.

## Mining underground

- Flood-resistant motor design
- Maintenance-free submersible units
- Ready for use
- Install in vertical or horizontal positions
- Standard and bottom intake designs
- Delivery heads up to 800m (2,625 ft); flows up to 8,000m<sup>3</sup>/h (35,225 USGPM)

## Deep well pumping in open-pit mines

Open-pit drainage in demanding environments needs reliable and robust pump units that are resistant to corrosion. Pleuger's submersible pumps offer a broad operating range including slim designs for small well diameters, and they are ideal for significantly lowering water tables.

### Inclined pumping in open pit mines

Submersible Pump in booster shroud

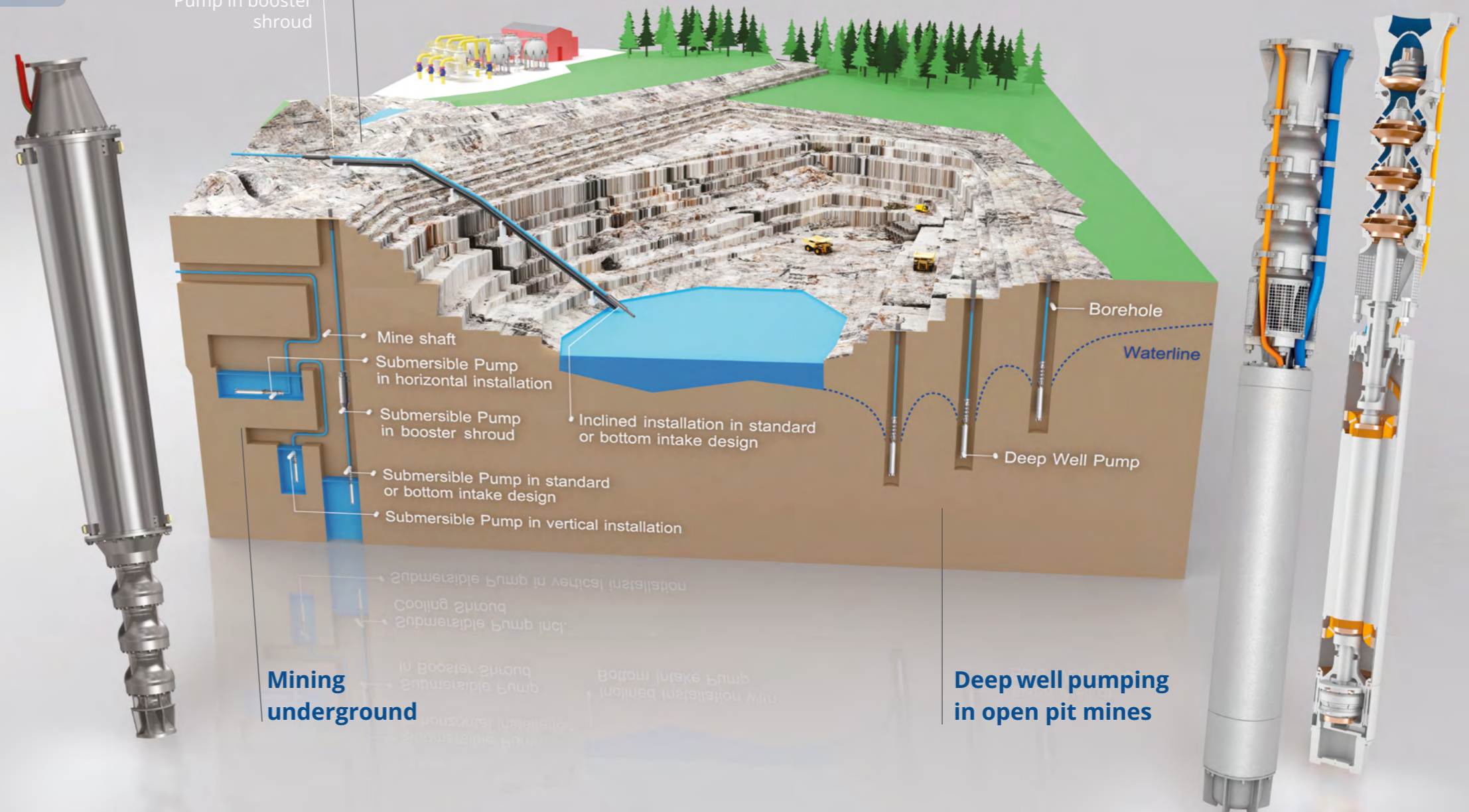

### Mining underground

### Deep well pumping in open pit mines

# THE BEST CHOICE FOR THE MINING SECTOR

We specialize in the design and development of custom pump units for severe operational conditions within the mining sector. Pleuger's single and multistage submersible motor pumps are reliable, efficient and durable. Our units are ready for action 24 hours a day, 365 days a year, and they guarantee consistently reliable performance.

Our designs offer significant benefits for mining pump applications, such as dewatering, water transfer and water supply:

- Reliable operation, even under extreme conditions
- Heavy-duty capacity in harsh environments
- Cost-effective lifecycle
- Maintenance-free
- Broad grades of materials, from Super Duplex stainless steel to bronze and cast iron
- Explosion-proof
- Space-saving installation in wells
- Flood- and freezeproof
- Efficient motors and pump solutions
- Reduced noise and vibration
- Optional installation accessories

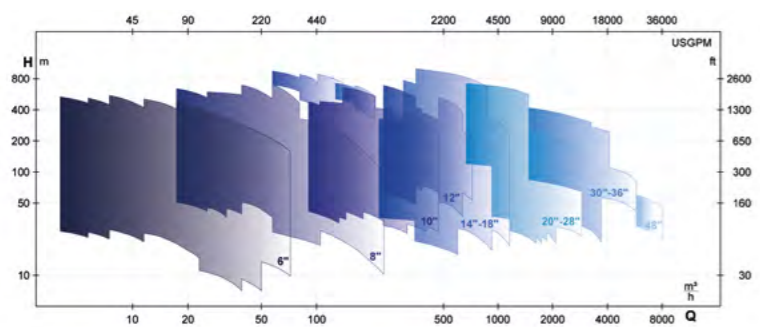
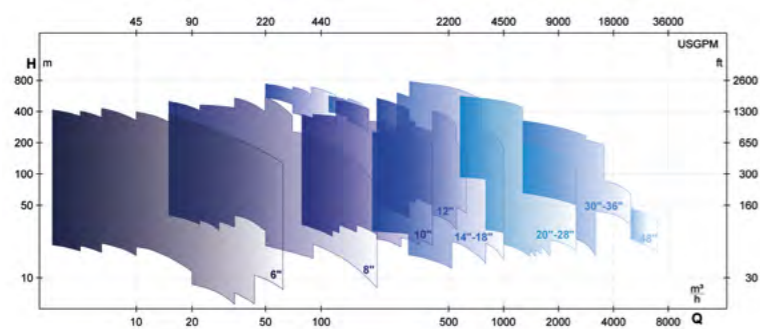

# DEEP WELL SUBMERSIBLE PUMPS

Our deep well centrifugal pumps are single-stage and multi-stage. Use them together with water-filled (standard) or oil-filled motors (custom). The motor is assembled between the suction area and the hydraulics. Motor sizes are available from 4" up to 50".

## Bottom intake pump

These centrifugal pumps can be single or multi-stage, and they should be used in combination with our water-filled motors. The motor is placed above the pump, and the intake is located in the pump's lower section. Our design reduces the water line to shallow levels. These pumps can be designed for vertical or inclined installations, according to your needs.

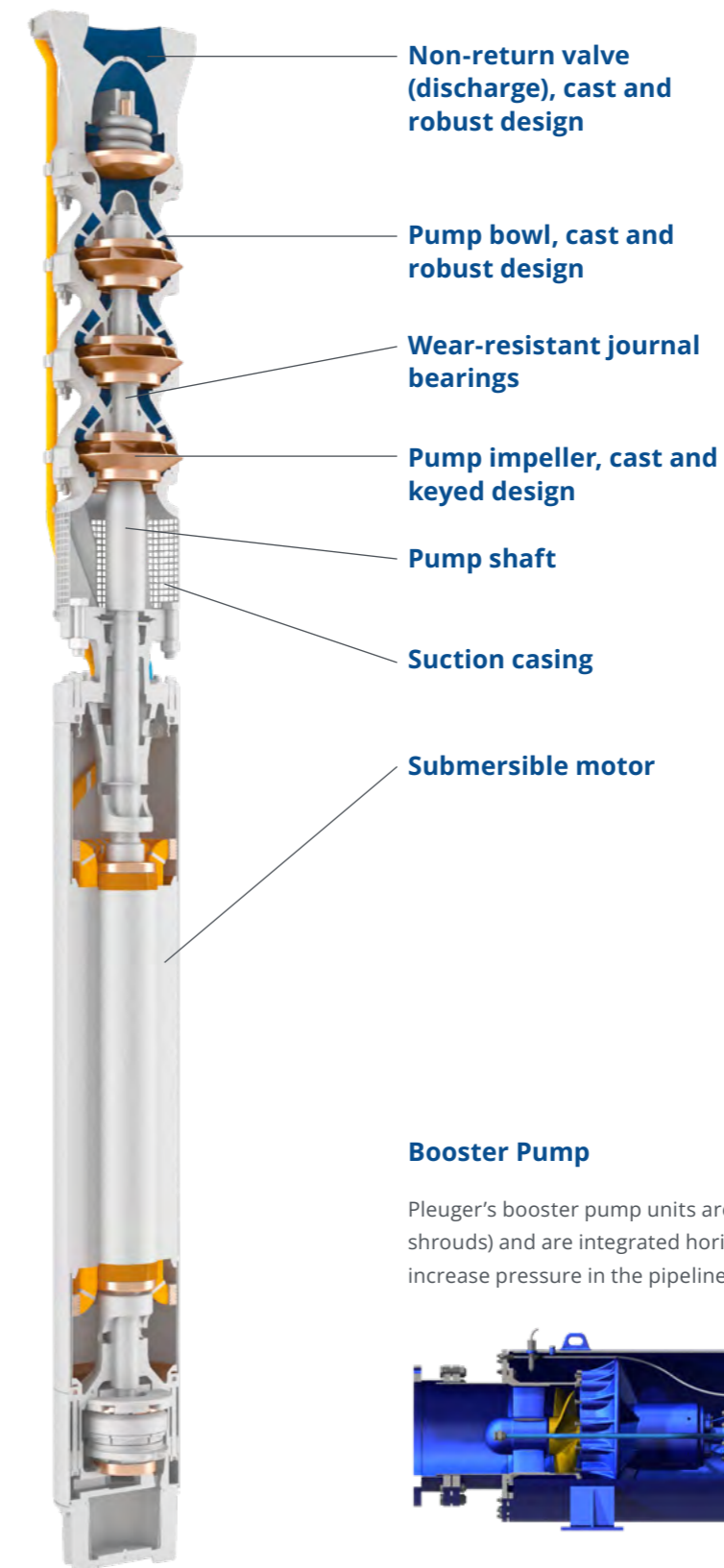

## Booster Pump

Pleuger's booster pump units are equipped with booster casings (pressure shrouds) and are integrated horizontally or vertically into the system to increase pressure in the pipeline networks.

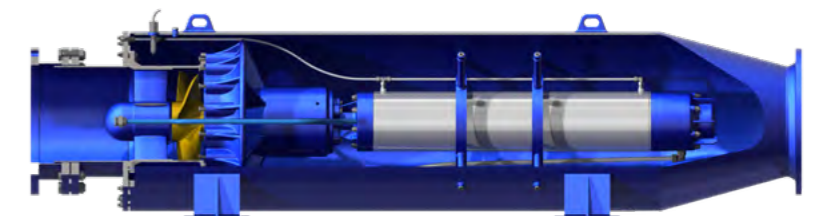

# OUR PROMISE FOR MOTOR TECHNOLOGY



## Custom motor solutions

Pleuger manufactures quality submersible motors with unique designs. We offer efficient corrosion protection customized to your project, and an extensive power range manufactured to Germany's thorough engineering standards.

## Technical data

- Water-filled motors (standard)
- Oil-filled motors (optional)
- Motor sizes from 6" to 50"
- Power output from 0.37 kW to 5 MW (0.5 HP to 6,700 HP)
- 230V to 6.6kV
- 3PH – 50Hz & 60Hz
- 2-pole (standard) to 12-pole motors available
- Suitable for VFD operation
- Sustains temperatures of -25°C to +100°C (-13°F to +212°F)

## Standards

- Design: ANSI / ASTM / DIN / ISO / Hydraulic Institute / CE marking / API 610
- Hydraulic: ANSI/HI / EN ISO / API610 / NFPA20
- Electrical: NEMA / IEC / IEEE
- Certifications: DNV GL / ABS / CSA / ATEX
- Approvals: ISO 9001

## Lifecycle cost solutions

Typically, a pumping system's total lifecycle cost (LCC) can only be calculated after the equipment has been purchased and installed. Energy costs account for 90% of this.

Pleuger's suite of solutions saves considerable time and money to customers throughout the pumping system's life span.

Our solutions facilitate every part of the lifecycle, including capital and operating costs.

**The perfect fit for our permanent magnet motor technology and hydraulics**

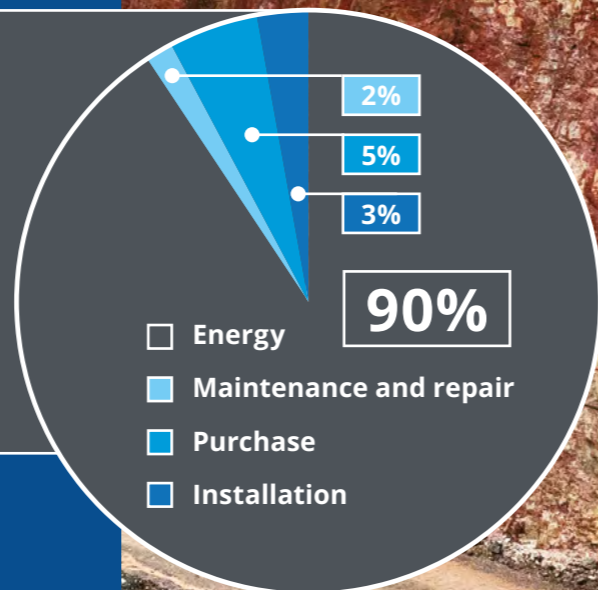

# ROBUST MOTOR DESIGN TO MINIMIZE LIFECYCLE COSTS

## Flat or round cable

Space-saving cable design for installations in sites with limited space

## NEMA flange connection

Connects easily to standard hydraulics

## Motor housing

Robust cast housing ensures strength, rigidity, corrosion resistance and durability.

## Induction motor: Squirrel-cage motor for asynchronous motor,

or

## Permanent magnet motor: Rotor equipped with permanent magnets for synchronous motor

- No copper losses increase motor efficiency by up to 14% compared to asynchronous motors.
- Hermetic, encapsulated rotor protects magnets against corrosion and mechanical damage.
- Up to 200 kW (268 HP) available.

## Rewindable winding

Economically efficient and PE2 insulation.

## Rubber diaphragm

Guarantees pressure and volume compensation of liquid inside and outside the motor to extend the mechanical seal and O-ring service life.

## Signal cable (optional)

Used with temperature sensor PT100 for monitoring motor temperature

## Motor shaft end

Standard duplex stainless steel construction ensures corrosion resistance, mechanical strength and rigidity. Special materials are available on request.

## Mechanical seal

Standard high-grade SIC/SIC/ Viton® ensures operations are maintenance-free and resistant to wear and tear.

## Stator tube

Standard 316 stainless-steel construction offers excellent corrosion resistance in the motor's lifecycle. Special materials are available on request.

## Motor filling

Prefilled and tested with water glycol mixture, or potable water on request.

## Thrust bearing

Heavy-duty, maintenance-free design to lengthen motor's lifetime. Developed by Pleuger inhouse.

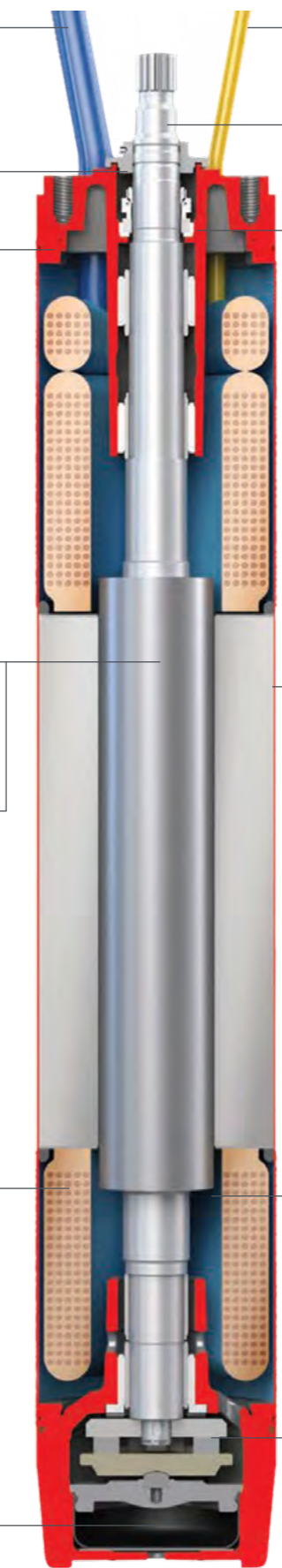

# MINING SOLUTIONS FOR CUSTOMERS WORLDWIDE

We attribute our global mining success to our multiple custom projects with renowned corporations. Sustainable growth is evident in all the regional markets in which we operate.

## OUR GLOBAL REACH

- Australia
- Bosnia and Herzegovina
- Canada
- Equatorial Guinea
- Estonia
- France
- Germany
- Ghana
- India
- Italy
- Jamaica
- Jordan
- Kyrgyzstan
- Madagascar
- Mauritania
- Morocco
- New Caledonia
- New Zealand
- Niger
- Papua New Guinea
- Peru
- Russia
- Saudi Arabia
- Singapore
- South Africa
- Spain
- Tanzania
- Tunisia
- Turkey
- United Kingdom
- United States of America
- Uzbekistan
- Zimbabwe

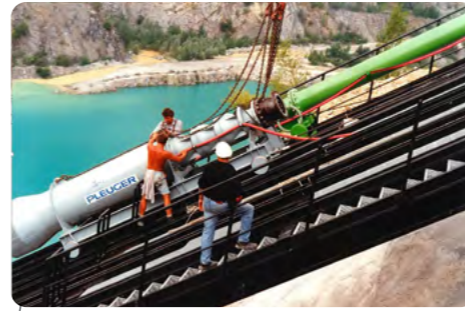
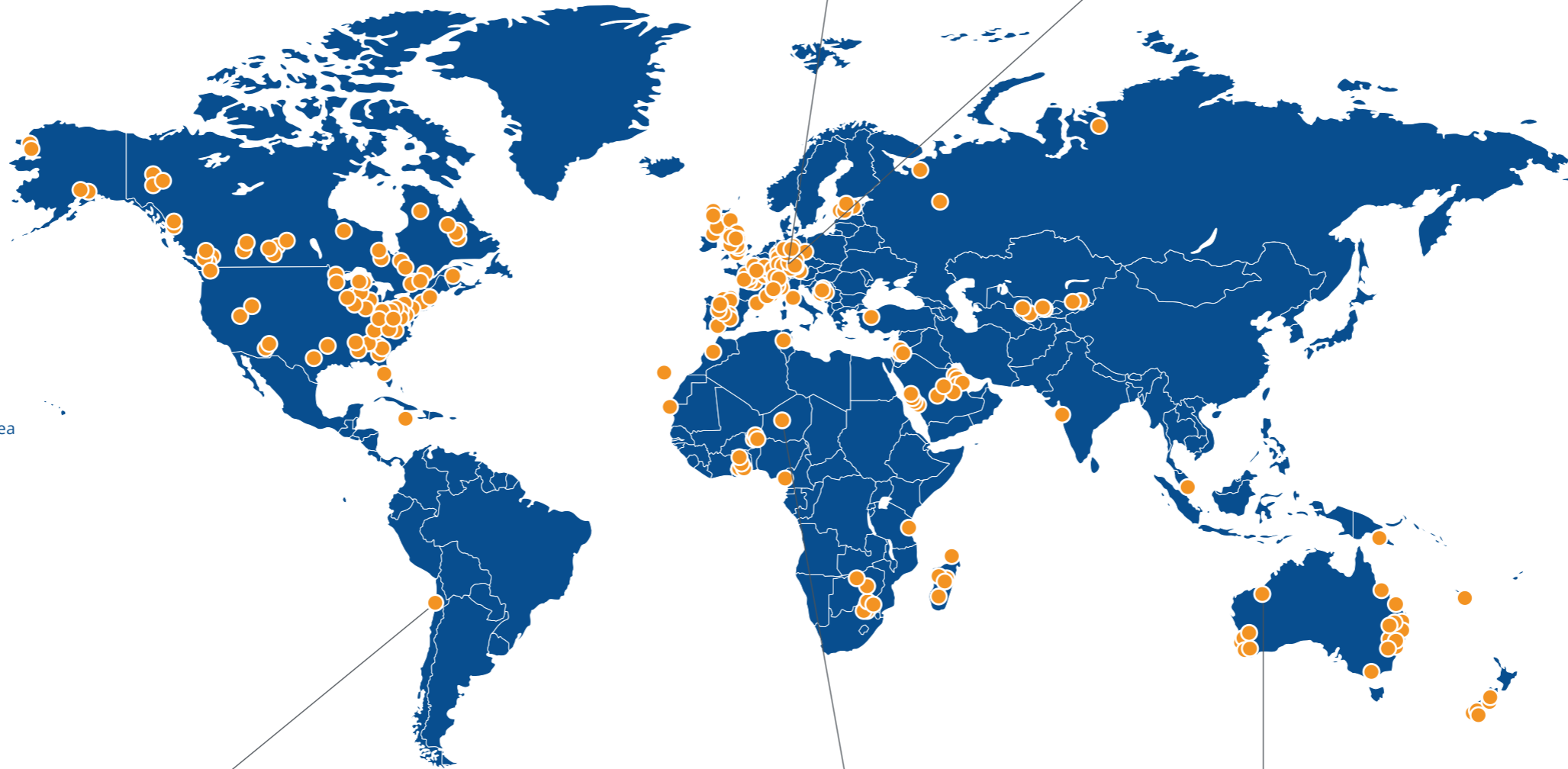

Wülfrath, Germany: Inclined installation of our submersible pumps, used for limestone mining.



Lausitz, Germany: The opencast mines produce 60 million tons (66 million US tons) of lignite per year.



Northern Chile: The Copper mine at Collahuasi is situated at an altitude of 4000 m (13,123 ft). Long-term capacity reaches around 500,000 tons (551,156 US tons) per year.



Northern Niger: Uranium mining has a production capacity of 3000 tons (3,307 US tons) per year.



Western Australia: Operations at the Christmas Creek iron ore mine are combined with mining activities at Cloudbreak.

## Pleuger in the Press

*"Pleuger gets things flowing at Collahuasi"*

**Mining Magazine**

*"The German pump manufacturer has decades of experience in designing pump units for the special requirements of the mining sector"*

**World Pumps**

*"Collahuasi pump supplier brought Pleuger Industries into play because the German pump manufacturer has decades of experience in designing pump units"*

**Global Mining Review**

*"Pleuger's engineers have acquired their expertise in various customizing projects around the globe"*

**The Mining Review Zambia**

# WORLDWIDE SALES, SERVICE AND SUPPORT

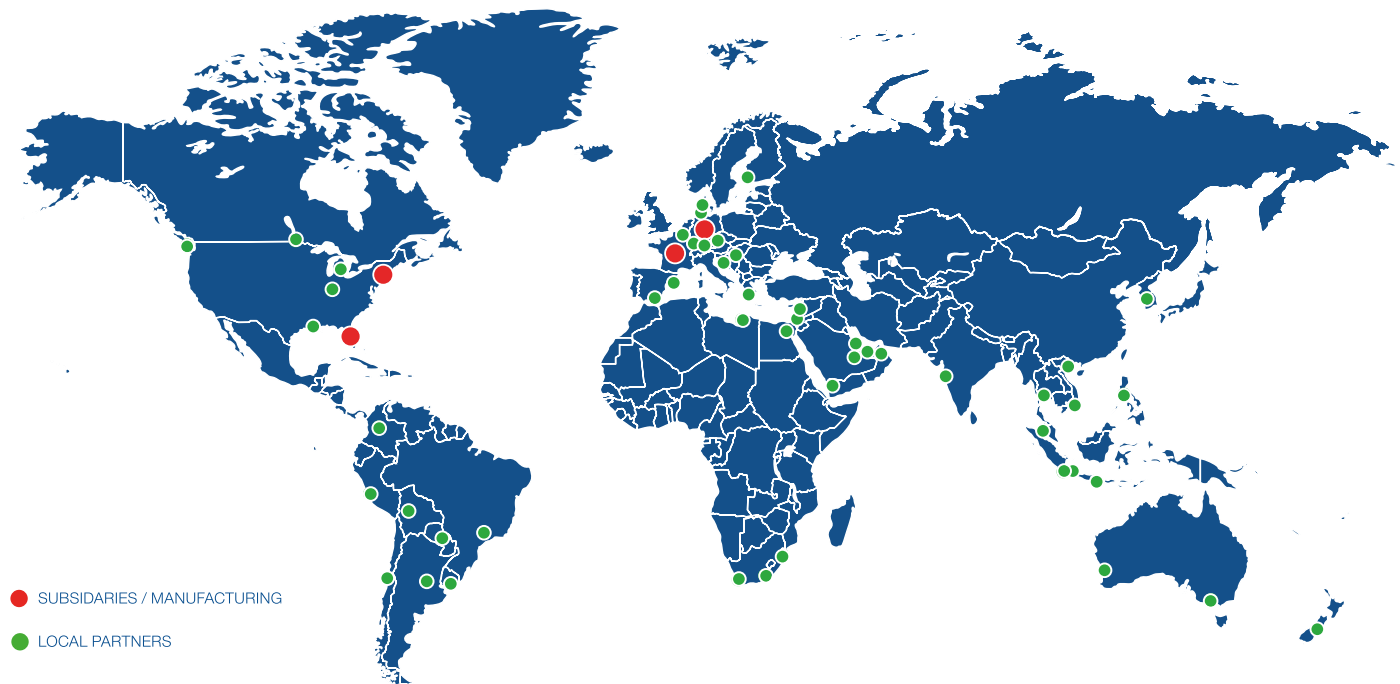

## THE RELIABILITY EXPERTS

PLEUGER designs, manufactures and services submersible motors, pumps, thrusters and plunger pumps. Renowned worldwide for absolute reliability and outstanding longevity throughout the energy, mining, water, industrial processing and oil & gas industries.

Our products perform in some of the most challenging and harshest of environments. PLEUGER engineers find solutions to some of the toughest challenges and are trusted across the globe as the reliability experts.

### PLEUGER LLC

1450 Brickell Avenue  
Suite 1900 Miami 33131, Florida USA  
miami@pleugerindustries.com

### PLEUGER Industries GmbH

Friedrich-Ebert-Damm 105  
22047 Hamburg  
Germany

Tel: +49 (0) 40 69 689 770  
hamburg@pleugerindustries.com  
Spare Parts Tel. 49 (0) 40 69 689 200  
spareparts@pleugerindustries.com

### PLEUGER USA

3240 Winsted Rd  
Torrington, CT 06790  
United States of America

Tel: +1 860 482 8345  
Pleugerusa@pleugerindustries.com

### PLEUGER INDUSTRIES FRANCE

21, Rue de la Mouchetière Parc d'activités  
d'Ingré, F - 45140 Saint-Jean de la Ruelle  
France

Tel: +33 (0) 2 38 70 84 00  
orleans@pleugerindustries.com



# PLEUGER

[www.pleugerindustries.com](http://www.pleugerindustries.com)

Made in Germany